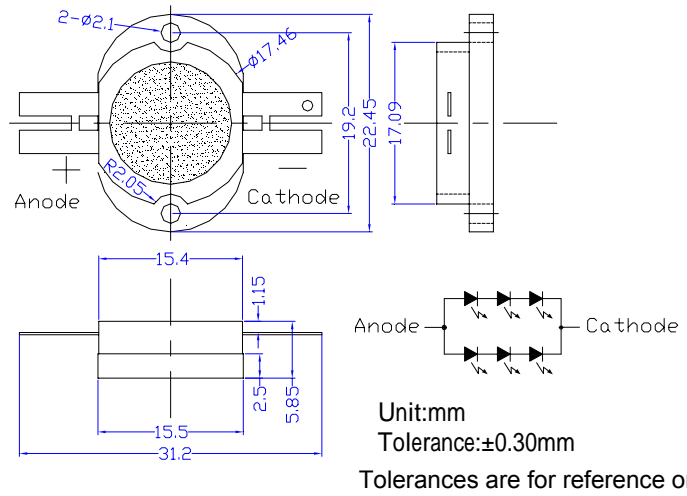

■ Features

- High-power LED
- Long lifetime operation
- Typical viewing angle : 140deg
- RoHS compliant
- Possible to attach to heat sink directly without using print circuit board.

■ Applications

- Indoor & outdoor lighting
- Stage lighting
- Reading lamps
- Display cases, furniture illumination, marker
- Architectural illumination
- Spotlights

■ Outline Dimension

■ Absolute Maximum Rating (Ta=25 °C)

Item	Symbol	Value	Unit
DC Forward Current *1	I_F	1,400	mA
Pulse Forward Current*2	I_{FP}	2,000	mA
Reverse Voltage	V_R	15	V
Power Dissipation*1	P_D	15,960	mW
Operating Temperature	T_{opr}	-30 ~ +85	
Storage Temperature	T_{stg}	-40 ~ +100	
Lead Soldering Temperature	T_{sol}	260 /5sec	-

*1, Power dissipation and forward current are the value when the module temperature is set lower than the rating by using an adequate heat sink.

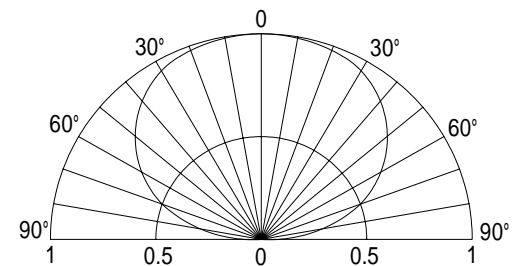
*2, Pulse width Max.10ms Duty ratio max 1/10

■ Directivity

Electrical -Optical Characteristics (Ta=25 °C)

Item	Symbol	Condition	Min.	Typ.	Max.	Unit
DC Forward Voltage	V_F	$I_F=1000mA$	8.7	10	11.4	V
DC Reverse Current	I_R	$V_R=15V$	-	-	20	μA
Luminous Flux	ν	$I_F=1000mA$	750	850	-	lm
Color Temperature	CCT	$I_F=1000mA$	-	6500	-	K
Chromaticity Coordinates*	x	$I_F=1000mA$	-	0.31	-	
	y	$I_F=1000mA$	-	0.34	-	
50% Power Angle	$2\theta_{1/2}$	$I_F=1000mA$	-	140	-	deg

Note: Don't drive at rated current more than 5s without heat sink for High Power series.

* Tolerance of chromaticity coordinates is $\pm 10\%$, * Tolerance of Luminous Flux is $\pm 20\%$

Heat design

The following pictures show some measurements of mounted 5W Led on the heat sink for each board A and B (See Fig 1) with using thermograph to make an observation about heat distribution. Each boards is tested at various current conditions.

As a result, LED needs larger heat sink as much as possible to reduce its own case temperature.

Fig. 1 Configuration pattern examples for board assembly

Board	LED power	Material	Surface area (mm ²) Min.
A	5W	Al	10,300
B	10W	Al	20,600
C	25W	Al	51,500
D	50W	Al	103,000
E	100W	Al	206,000
F	200W	Al	412,000
G	300W	Al	618,000

Above tested LED device is attached with adhesive sheet to the heatsink.

For reference's sake, Tj absolute maximum rating is defined at 115 as a prerequisite on design process of 5W LED.

<Fig.2> Board A (surface area=10,300mm²)

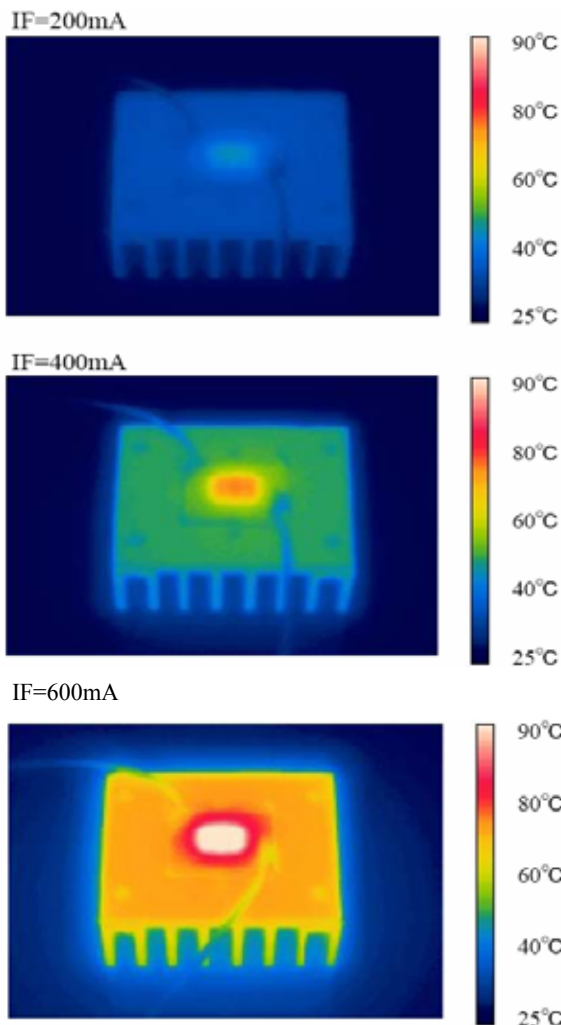

<Fig.3> Board B (surface area=20,600mm²)

